

Specifications of servo motor

Voltage level	220V						
	60ST-		80ST-		90ST-	110ST-	
Motor type MS-	M00630	M01330	M02430	M03520	M02430	M04030	M05030
Motor code	1003	0004	0011	0012	0021	0031	0032
Rated power (KW)	0.2	0.4	0.75	0.75	0.75	1.2	1.5
Rated current (A)	1.8	2.5	3.0	3.0	3.0	5.0	6.0
Rated speed (rpm)	3000	3000	3000	2000	3000	3000	3000
Max speed (rpm)	4000	4000	4000	2500	4000	3500	3500
Rated torque (N.m)	0.637	1.27	2.39	3.5	2.4	4	5
Peak torque (N.m)	1.91	3.8	7.1	10.5	7.1	12	15
Back EMF constant (V/krpm)	26	28	48	48	51	54	62
Torque coefficient (N · m/A)	0.37	0.5	0.8	0.8	0.8	0.8	0.83
Rotor inertia (Kg · m ²)	0.18 × 10 ⁻⁴	0.438 × 10 ⁻⁴	0.24 × 10 ⁻³	0.24 × 10 ⁻³	0.24 × 10 ⁻³	0.54 × 10 ⁻³	0.63 × 10 ⁻³
Winding resistor (Ω)	35	3.49	2.88	2.88	3.2	1.09	1.03
Winding inductance (mH)	8.32	8.47	6.4	6.4	7.0	3.3	3.43
Electrical time constant (ms)	2.38	2.4	2.22	2.22	2.2	3.0	3.33
Weight (Kg)	1.11	1.78	2.86	2.86	3.4	5.5	6.1
Encoder ppr (PPR)	2500						
Pole pairs	4						
Motor insulation level	Class B(130°C)						
Protection level	IP64		IP65				
Using ambient	Ambient temperature: -20°C~+50°C Ambient humidity: Related humidity <90% (no condensation)						

Voltage level	220V				380V				
	130ST-		180ST-	180ST-	180ST-		180ST-		
Motor type MS-	M06025	M10015	M07725	M15015	M19015	M21520	M27015	M35015	M48015
Motor code	0042	0044	0043	0046	0052	0150	0131	0152	0153
Rated power (KW)	1.5	1.5	2.0	2.3	3.0	4.5	4.3	5.5	7.5
Rated current (A)	6.0	6.0	7.5	9.5	12.0	9.5	10	12.0	20.0
Rated speed (rpm)	2500	1500	2500	1500	1500	2000	1500	1500	1500
Max speed (rpm)	3000	2000	3000	2000	2000	3000	2000	2000	2000
Rated torque (N.m)	6	10	7.7	15	19	21.5	27	35	48
Peak torque (N.m)	18	25	22	30	47	53	67	70	96
Back EMF constant (V/krpm)	65	103	68	114	97	140	172	113	156
Torque coefficient (N · m/A)	1.0	1.67	1.03	1.58	1.58	2.26	2.7	1.84	2.4
Rotor inertia (Kg · m ²)	1.26 × 10 ⁻³	1.94 × 10 ⁻³	1.53 × 10 ⁻³	2.77 × 10 ⁻³	3.80 × 10 ⁻³	4.7 × 10 ⁻³	6.1 × 10 ⁻³	8.6 × 10 ⁻³	9.5 × 10 ⁻³
Winding resistor (Ω)	1.21	1.29	1.01	1.1	0.4	0.71	0.796	0.21	0.273
Winding inductance (mH)	3.87	5.07	2.94	4.45	2.42	4	4.83	1.57	2.14
Electrical time constant (ms)	3.26	3.93	3.80	4.05	6	5.6	6	7.47	7.8
Weight (Kg)	8.9	11.5	10	14.4	20.5	22.2	25.5	30.5	40
Encoder ppr (PPR)	2500								
Pole pairs	4								
Motor insulation level	Class B(130°C)								
Protection level	IP65								
Using ambient	Ambient temperature: -20°C~+50°C Ambient humidity: Related humidity <90% (no condensation)								

Match table of motor and drive

Motor type	Motor code	Matched drive	Voltage level
MS-60ST-M00630-20P2	1003	DS2-20P2-AS	single-phase/3-phase 220V
MS-60ST-M01330-20P4	0004	DS2-20P4	single-phase 220V
		DS2-20P4-AS/-A/-B	single-phase/3-phase 220V
MS-80ST-M02430-20P7	0011	DS2-20P7	single-phase 220V
		DS2-20P7-AS/-A/-B	single-phase/3-phase 220V
MS-80ST-M03520-20P7	0012	DS2-20P7-AS/-A/-B	single-phase/3-phase 220V
		DS2-20P7	single-phase 220V
MS-90ST-M02430-20P7	0021	DS2-20P7-AS/-A/-B	single-phase/3-phase 220V
		DS2-21P5	single-phase 220V
MS-110ST-M04030-21P2	0031	DS2-21P5-A	3-phase 220V
		DS2-21P5-B	
		DS2-21P5-AS	

Motor type	Motor code	Matched drive	Voltage level
MS-110ST-M05030-21P5	0032	DS2-21P5	single-phase 220V
		DS2-21P5-A	3-phase 220V
		DS2-21P5-B	
		DS2-21P5-AS	
MS-130ST-M06025-21P5	0042	DS2-21P5-A	3-phase 220V
		DS2-21P5-B	
		DS2-21P5-AS	
MS-130ST-M10015-21P5	0044	DS2-21P5-A	3-phase 220V
		DS2-21P5-B	
		DS2-21P5-AS	
MS-130ST-M07725-22P0	0043	DS2-22P3-A	3-phase 220V
MS-130ST-M15015-22P3	0046	DS2-22P3-A	
MS-180ST-M19015-23P0	0052	DS2-23P0-A	
MS-180ST-M21520-44P5	0150		
MS-180ST-M27015-44P3	0151	DS2-45P5-A	3-phase 380V
MS-180ST-M35015-45P5	0152		
MS-180ST-M48015-47P5	0153	DS2-47P5-A	

stable performance
easy operation



DS2 series servo drive

Features of DS2 servo drive

Good performance

Support position control, speed control, torque control. Any two of the control modes can switch.

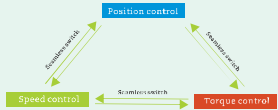

Flexible configuration

- 2 channels high speed pulse input, max frequency is 500KHz; 2 channels 12-bit -10~+10V analog input.
- 6 channels SI input and 3 channels SO output can be defined freely. Output signal options: encoder open collector mode and difference mode, 1 channel Z-phase original signal transistor output.

High response frequency

Up to 400Hz high speed frequency response.

Easy terminals

Common I/O signal is Euro terminal, no need to solder. Such as pulse input signal, alarm output signal.

Two ports communication

- Port1 can connect PC to debug the servo drive with servo software
- Port2 is RS485 terminal, support MODBUS-RTU protocol.

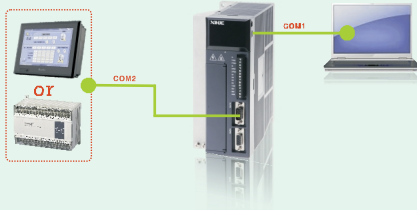

RS485 bus

Easy, fast control based on RS485 bus.



Safe and reliable

IGBT can withstand high voltage up to 1200V; high speed DSP control is more reliable; wide voltage input range: 200V-240V, 310V-450V; outstanding noise immunity ability, suitable for bad electromagnetic environment.

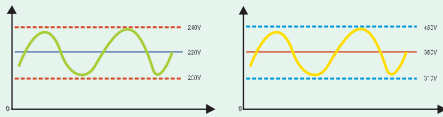

Applied to many kinds of industry

Various control modes and interfaces, enhanced communication functions, apply to many industries such as grinder, lathe, packing machine, carving machine, bending machine, plate-cutting machine, etc.



Accurate positioning

Advanced digital control algorithm makes the control of current loop, speed loop and position loop accurately.

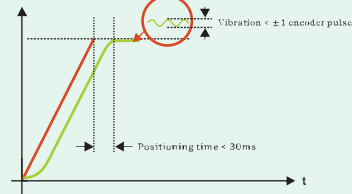

Complete protection

Over voltage, under voltage, over current, over speed, over load, encoder error, too large position shifting.

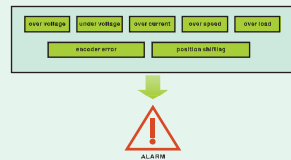

Easy operate interface

Display the servo state through operator, there are 16 monitor parameters and error message.

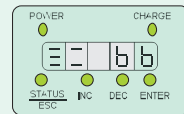

Debugging software

- Debug the servo through PC
- The software support multi-language
- Support parameter read & write/state monitor/gain adjustment/jog running
- Support emulate digital oscilloscope, record the motor curve, easy to analyze motor characteristics.

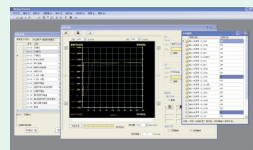

Applications of DS series servo



Position, speed and torque control

Functions:

The control modes of DS series servo include position, speed, torque. The diagram shows the liquid filling machine. The belt will stop when detected the products. The position control motor ensures the positioning of the belt. The motor is running to fill the liquid. The liquid is full when reach certain torque. The torque control motor ensures the liquid height in the bottles. The speed control motor runs forward or backward to press the liquid into the hydraulic cylinder.

Any two modes can switch seamlessly; the torque can be limited in position or speed mode.

More applications:

Liquid filling machine, packing machine, screw tightening machine, butt-welding machine.

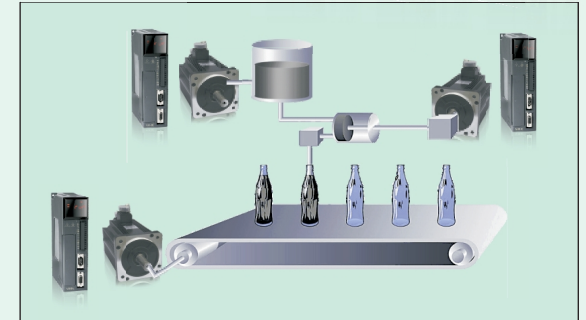

Interruption control

Functions:

The servo goes uncertain distance in internal position mode. It will go certain distance when detected the external sensor signal. The output signal will start the next process after positioning end. The laser printer will go to the next positioning process when photoelectric switch touches the workpiece. The printer will print after positioning end. High speed interruption will deal with the photoelectric switch signal and ensure the printer position.

No need any controllers positioning, high positioning precision can meet the requirements.

More applications:

Product line of laser printer, pipe cutting machine.

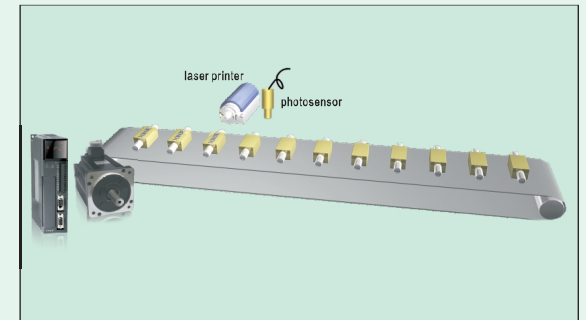

Synchro-position control

Functions:

Feeding-roller run certain distance, cutting-film roller followed it to turn certain angle, sending-film roller run certain distance. The servo will ensure the consistency of the three rollers' height and the stability of running speed. The smoothness of speed control, position control, torque control can be adjusted through filter parameter. It also can adjust the smoothness of the whole motions and avoid skid.

Any two modes can switch seamlessly; the torque can be limited in position or speed mode.

More applications:

Die cutting machine, feeding machine.

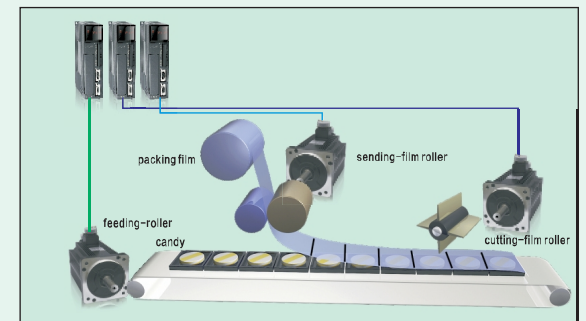

The name rule, specifications and configuration of servo

Applications of simple machine

Switching gate can control the ticket entrance.
 Dividing plate can be used to switch the tools of numerical control machine.
 Conveyor belt can be used to control the position of various materials.
 Spiral sliding table is applied to flush coater, carving machine.
 mixing device can be used to washing machine, stirring machine/roller is used to calico printing machine, paper cutting machine.

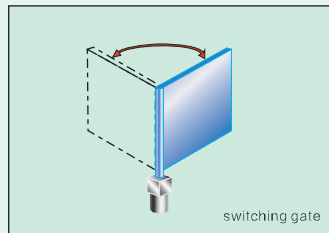
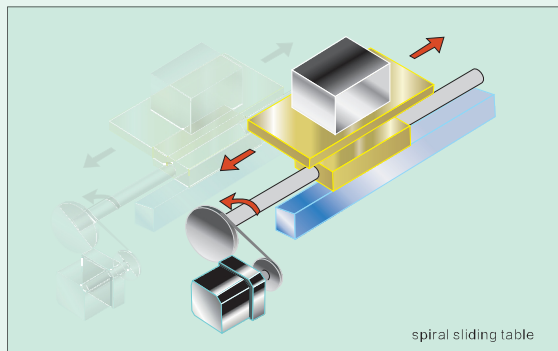
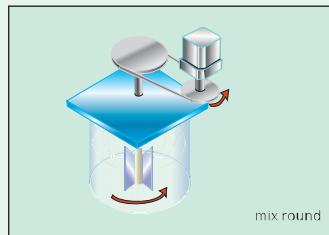
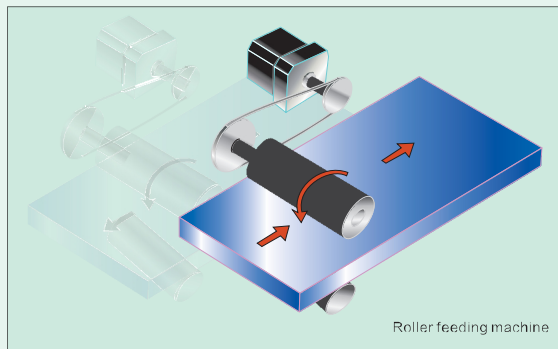
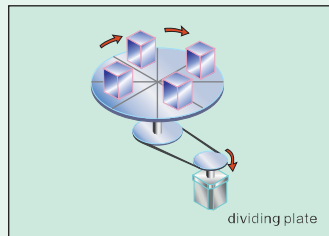
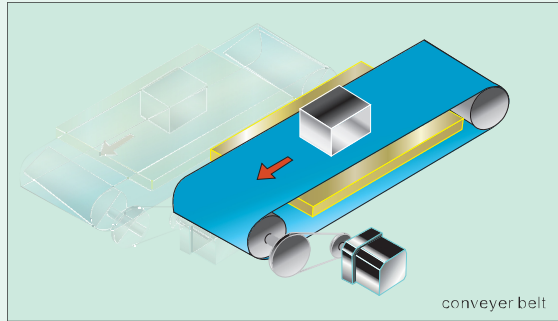

The name rule of servo drive

DS2 - 2 1P5 - A

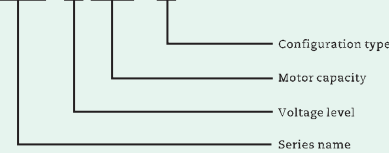

Configuration type	Nothing (basic configuration)	
	Type A (with DB15 port)	Type B (with DB15 port)
Matched motor capacity	0P2	0.2KW
	0P4	0.4KW
	0P7	0.75KW
	1P5	1.5KW
	2P3	2.3KW
Voltage level	3P0	3.0KW
	5P5	5.5KW
	7P5	7.5KW
	2	220V
	4	380V

Specifications of servo drive

		Item	Specification
basic spec	input power	0.2~0.75 KW: single phase 220V 0.75~1.5KW: single-phase/3-phase 220V 2.3~3.0KW: 3-phase 220V 5.5KW: 3-phase 380V	
		feedback	incremental 2500 ppr
	using condition	use/storage temperature	0~+50℃ /20~+85℃
		use/storage humidity	below 90% RH (no condensation)
speed torque control mode	performance	speed control range	1:4000 (lower limit of speed control range, no stop at rated torque load)
		speed change	load change
	voltage change		rated voltage ±10% 0% (at rated speed)
	temperature change		20 ± 25℃ below ±0.1% (at rated speed)
	frequency features	250Hz(L≤JM)	
	soft start time	0~65535ms (set acceleration and deceleration)	
position control mode	input signal	set through RS485 communication, DC10V/rated speed, torque (set through parameters)	
		feedforward compensation	0~100% (resolution is 1%)
	performance	positioning end width	0~250 command unit (resolution is 1 command unit)
		input signal	command pulse
control signal	clear signal (CLR)		
I/O signal	position output		output mode
		divider ratio	1:1
	input signal	external input terminals	up to 6 input terminals
		changeable signal distribution	/S-ON, /P-CON, /P-OT, /N-OT, /ALM-RST, /PCL, /NCL, /SPD-D, /SPD-A, /SPD-B, /C-SEL, /2CLAMP, /CLR, /INHIBIT, /G-SEL, /CHGSTP
output signal	external output terminals	up to 3 output terminals	
	changeable signal distribution	/COIN, /V-CMP, /FGON, /S-RDY, /CLT, /VLT, /BK, /WARN, /SEAR, /ALM, /Z	
built-in function	dynamic brake (DB)	no	
	regeneration function	built-in regeneration unit, external regeneration resistor	
	over range limit	when P-OT, N-OT act, deceleration stop or inertia stop	
	electronic gear	0.01~B/A≤100	
communication	protection function	program error, parameter error, over voltage, under voltage, regeneration error, over heat, over current, over speed, analog input error, position deviation overflow, output short circuit, current error, encoder wire cut-off, encoder error, overload, power-off when running, write parameter error...	
		LED display	charging, power supply, 7-segment LED × 5 (built-in digital operation function)
	COM1	connection device	RS232, connect to PC
		serial port parameter function	baud rate 19200; data bit 8; stop bit 1; communication protocol: Modbus-RTU slave device; Modbus station no. 1 debug online
COM2	connection device	RS485, connect to PLC, HMI, PC	
	serial port parameter main function	serial port parameters can be set, communication protocol: Modbus-RTU slave device; Modbus station no. can be set state display, user parameters settings, monitor display, alarm display, special control, online debug	

Configuration of servo drive

Series	Type	Input power	Analog input	Digital input	Digital output	Position command input mode			AB phase feedback		Z phase feedback		
						Difference	24VOC	5VOC	Difference	OC	Difference	OC	
DS2	DS2-20P4	1PH 220V 50HZ	x	2	2	x	√	x	x	x	x	√	x
	DS2-20P7					x	√	x	x	x	√	x	
	DS2-21P5					x	√	x	x	x	√	x	
	DS2-21P5-A					x	√	x	x	x	√	x	
	DS2-22P3-A	3PH 220V 50HZ	√	6	3	√	√	x	√	x	√	√	
	DS2-23P0-A					√	√	x	√	x	√	√	
	DS2-45P5-A	3PH 380V 50HZ	√	6	3	√	√	√	x	√	x	√	
	DS2-47P5-A					√	√	√	x	√	x	√	
	DS2-21P5-B	3PH 220V 50HZ	√	6	3	√	√	√	√	x	√	x	
	DS2-20P2-AS					√	√	√	√	x	√	x	
	DS2-20P4-AS	1/3PH 220V 50HZ	√	5	3	√	√	√	√	x	√	x	
	DS2-20P7-AS					√	√	√	√	x	√	x	
	DS2-21P5-AS	3PH 220V 50HZ	√	5	3	√	√	√	√	x	√	x	

Dimensions of servo drive (unit: mm)

• DS2-20P4、DS2-20P7

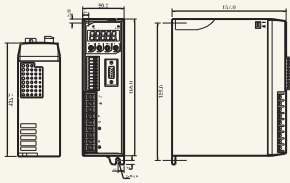

• DS2-2□P□-A、DS2-2□P□-B

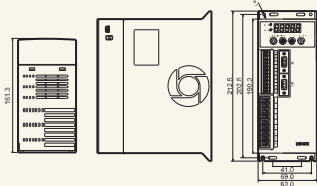

• DS2-20P2/20P4/20P7-AS

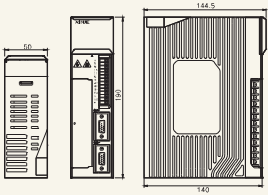

• DS2-47P5-AS

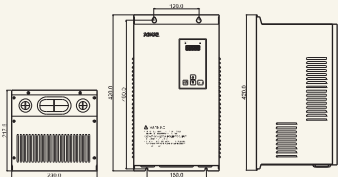

• DS2-21P5

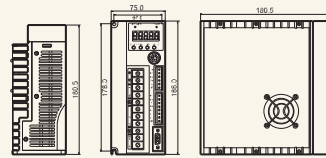

• DS2-45P5-A

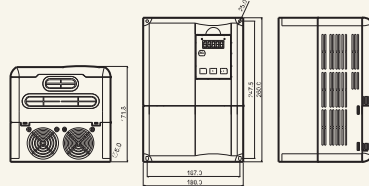

• DS2-21P5-AS

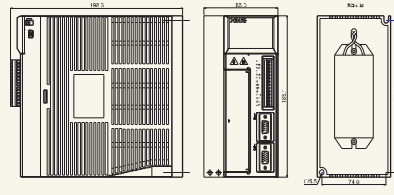

Name rule of servo motor type

MS-80 ST - M 02430 A Z - 2 0P7

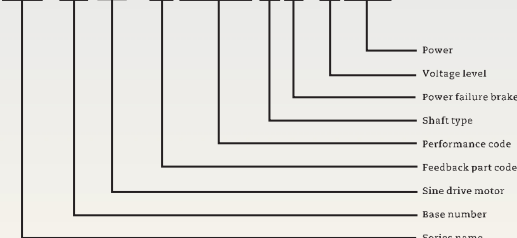

Base no.	60、80、90、110、130、180
Feedback part code	M Optical pulse encoder
Performance code	First 3-bit is rated torque; last 2-bit is rated speed Examples: 00630: rated torque 0.6 N.m, rated speed 3000 rpm; 06025: rated torque 6.0 N.m, rated speed 2500 rpm; 19015: rated torque 19.0 N.m, rated speed 1500 rpm;
Shaft type	A no bond B with bond
Power failure brake	- no Z with power failure brake
Voltage level	2 220V 4 380V
Power	Example: 0P4 is 0.4KW; 0P7 is 0.75KW; 3P0 is 3.0KW

Dimensions of servo motor

Mounting dimensions of servo motor(unit: mm)

• 60 series motor

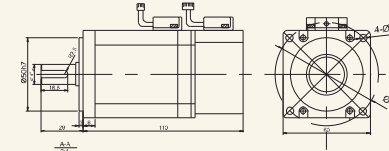

type	LA	
	General	With brake
MS-60ST-M00630 -20P2	146	189

• 80 series motor

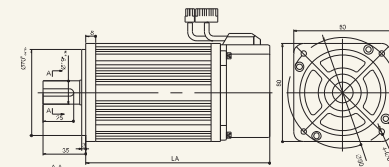

type	LA	
	General	With brake
MS-80ST-M02430 -20P7	150	191
MS-80ST-M03520C -20P7	178	219

• 110 series motor

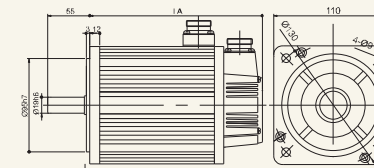

type	LA	
	General	With brake
MS-110ST-M04030C -21P2	189	263
MS-110ST-M05030C -21P6	204	278

• 180 series motor

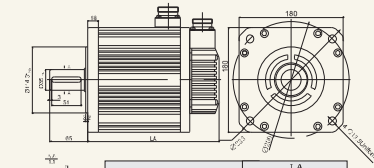

type	LA	
	General	With brake
MS-180ST-M19015 -23P0	232	289
MS-180ST-M21520 -L-44P5	245	300
MS-180ST-M27015 -L-44P3	262	319
MS-180ST-M35015 -F-45P5	292	349
MS-180ST-M48015 -F-47P5	316	403

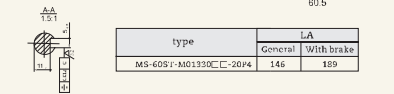
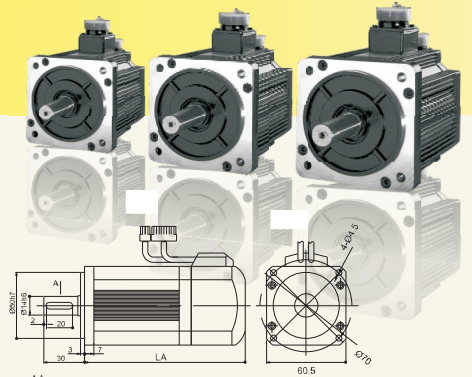

• 90 series motor

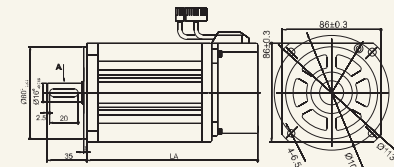

type	LA	
	General	With brake
MS-90ST-M02430 -20P7	149	194

• 130 series motor

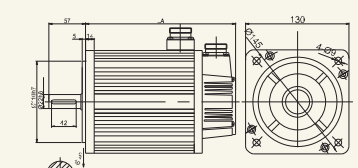

type	LA	
	General	With brake
MS-130ST-M06025 -21P5	179	263
MS-130ST-M07225 -22P0	192	249
MS-130ST-M10015 -21P5	213	270
MS-130ST-M15015 -22P3	241	298

★ The differences of general type and type with brake

